

Home entertainment. The choice is yours.

Access**TV**
userguide



 **ccess**
COMMUNICATIONS CO-OPERATIVE



Important Numbers

24/7 Customer Service 1-866-363-2225

For all customer care & billing inquiries, to set up new services, change existing services or for product information

Press 1

Reporting trouble with existing services

Press 2

For office hours, retail locations or to speak to our receptionist

Press 3

Fax (Head Office)

306-565-5395

For general customer service inquiries email:

customer.care@myaccess.coop

AccessTV

Build a package that suits your needs. AccessTV offers all the flexibility and choice you've always wanted! If you love movies, sports, entertainment and crystal clear HD - we've got you covered.

The hardest part about enjoying AccessTV will be making the popcorn.

AccessTV offers great features including:*

- Access7 - Great Local Programming
- One Free Box Rental
- TV Listings Channel With Community-Specific Ads
- Access**OnDemand**
- Pay-Per-View
- Premium Movie Packages
- Digital Music Channels
- Free Installation and Service Calls
- A Wide Selection of Channels
- Options To Upgrade At Any Time
- High Definition Channels
- Access**TV ToGo**
- Interactive Program Guide
- Specialty Channels
- Personal Video Recorders

*Availability of features may vary by community.

Table of contents

Digital boxes	3	DCX700	11
Access TV ToGo	4	DCX3200	12
Access OnDemand	5	DCT3412/3416	13
Pay-Per-View	6	TDC777D	14
How to use your guide	6	DC550D	15
How to use your remote	7	DCX3520	16
Parental controls	8	DCX3400	17
Box Hook Ups		DCX3501	18
DCT700	9	FAQs	19-22
DCX525	10		

Digital boxes

PVR

This box allows you to control live TV and record programs to watch later.

While you're watching a program live, your PVR records a digital copy allowing you to pause, rewind and fast-forward the show. Instant replays, bathroom breaks, catching an important line of dialogue all at your fingertips.

AccessEvo

This box is a multi-room PVR system - record up to 6 shows at once and store 100 hours of HD programming. The gateway is the hub of the system and each TV you wish to connect will require a media player. Each media player includes a remote. AccessEvo also replaces any current hardware you may have for your AccessInternet and AccessPhone services

AccessEvo streamer

With our Evo streamer you can watch live TV and PVR recordings from anywhere in your house on your tablet or smartphone. Just connect to your home Wi-Fi network and you are ready to stream using the AccessEvo App.

AccessEvo Streamer has the ability to stream up to four devices at once in your home.

Equipment may not be exactly as shown. Product availability varies by community. Visit myaccess.ca for packaging in your community.

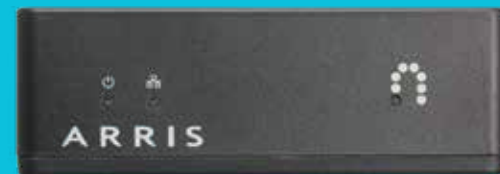

AccessTV ToGo

Watch TV everywhere

Cravetv™

Watch full seasons and full series of the most beloved shows ever on your TV, laptop, tablet and smartphone.

Networks ToGo

Enjoy your service in more places and on more screens than ever before.

Sign up instructions for AccessTV ToGo

1. Visit www.WatchTVEveryWhere.ca
Select your provider (Access Communications) then Click on "Register" and fill out your information. You will need to know your account number and the last name on your statement

Access will then automatically authenticate your details with our system and register you for the service. **This process may take up to 24 hours.**

2. You will receive your confirmation email with the activation link to log into WatchTVEveryWhere.ca.

Watching from a computer

Log into WatchTVEveryWhere.ca and click on the network link from your WatchTVEveryWhere account and start watching your favourite TV shows.

All of the content you are subscribed to will show up, just click on the link and start watching your favourite shows.

Watching on a mobile phone or tablet

Download the free Network Apps that you subscribe to, sign into the App on your mobile phone using your WatchTVEveryWhere username and password and start watching.

Log in information

Email:

Password:

Note: If you downloaded the Network App before signing up for WatchTVEverywhere, you will need to uninstall the App and reinstall the App and sign in, in order to get the authentication working properly.

If you need assistance, please contact us at 1-866-363-2225 or email help@myaccess.coop.

AccessOnDemand

Channel 200

Order movies, concerts, shows and all kinds of kids stuff right to your TV, whenever you want it!

Go to channel 200 or press “On Demand” or “VOD” on your remote, scroll to “VOD Tutorial” and hit “OK/Select” or visit myaccess.ca or youtube.com/myaccess.ca to view instructions on how to use Access**OnDemand**.

Pay Per View movies

Around-the-clock access to hundreds of movies, a ton in HD! These are the movies that are currently available for purchase anytime you want them. We keep adding to the list so check back often to see what's new!

Premium movie channels



You can watch some of the movies and shows currently playing on The Movie Network whenever you want. This is also where you'll find content from HBO - includes many of the series, mini-series and movies. If you subscribe to The Movie Network, you get it all for free!



It's here that you can watch some of the movies, series and specials you'll find on Super Channel. Best part: all the content here is free to Super Channel subscribers.

HOLLYWOODSUITE Playing movies 24/7, commercial-free, uncut and unedited, Hollywood Suite is the home of exclusive channels from major motion picture studios Warner Bros., MGM, Sony and AXN Movies. Free for Hollywood Suite subscribers.



Sports, arts and entertainment, local issues, and much more.

Networks

Content that networks make available for on demand delivery. As long as you subscribe to the network offering the content, you can watch for free!

Concert TV

View free concert samples and order full length concerts from a vast selection of great music shows.

Events

From Ultimate Fighter matches to hockey games - this is where you'll find replays of all kinds of special events.

The free zone

This programming is available to all Digital TV customers, anytime you want, and it's free! This is where you'll find things like music videos, karaoke and kids' programming.

Product availability varies by community. Visit myaccess.ca for packaging in your community.

Pay-Per-View

Access Pay-Per-View brings the latest blockbusters, exclusive concerts, and huge sporting events right into your living room. With easy to use on-screen ordering through your digital box, you are moments away from explosive entertainment, and you don't have to worry about late charges, long lines, or even leaving the comfort of your house!

Ordering with your remote control:

Standard Digital Boxes

1. Highlight the chosen movie in the on-screen guide.
2. Press OK/SELECT.
3. Press B on your remote control.
4. Highlight either 'Buy Event' or 'Buy Event and Set VCR Timer' and press either OK/SELECT or A on your remote control.

PVR and AccessEvo Digital Boxes

1. Highlight the selected movie in the on-screen guide.
2. Press OK/SELECT.
3. Highlight either 'Buy This Show' or 'Buy and Record This Show' and press OK/SELECT.

Ordering with the automated phone system:

1. Call 1-866-994-6778.
2. Follow the prompts to select and order a movie.

Ordering through Customer Care:

Call 1-866-363-2225 to speak to a Customer Care Representative.

How to use your guide

How to use your guide

Our digital guide can tell you what's on TV, but that's just the beginning. Get detailed information about programs, set times to watch shows in the future, search for titles and set parental controls and favourites.

The guide

Press “GUIDE” on your remote to find any show by time with up to seven lines of guide information and up to 2.5 hours viewing window (or scroll forward to check what's coming up), by theme with multiple categories, or through a quick title search feature.

Title search























Press “GUIDE” on your remote twice to search for shows by title, keyword, channel or theme.

Enhanced sort

Press the “A” button to sort by favourites, HD programs, or from custom made lists.

To download or print our Digital Guide Brochure visit myaccess.ca/tv

How to use your remote.

-  Turn set-top on/off
-  Displays Program Guide
-  Displays program information, (press once for channel banner, twice for Quick info)
-  Exits interactive menus
-  Displays or hides the Quick Settings menu
-  Navigates through days in the Time Grid
-  Navigates interactive menus
-  Navigates interactive menus
-  Selects the highlighted item
-  Turns sound on/off
-  Displays your list of recorded shows
-  Controls volume
-  Channel up/down
-  Quick scroll for interactive menu
-  On-screen menu options
-  Selects last channel
-  Rewind
-  Play
-  Fast Forward
-  Pause
-  Stop
-  Record



Parental control

How to set parental controls

Parental control is a valuable tool if there are some channels that you feel are not appropriate for some viewers in your family, or if you find the need to limit viewing for any reason.

Set Your PIN Number SD & HD Box

- To set your pin number, begin by pressing 'Menu' or 'Settings'.
- Use the 'Up/Down' arrows and highlight 'Parental Control'
- Press 'Ok/Select'.
- Press A to 'Set Pin'. Enter your 4-digit pin number and then re-enter the number.
- Press 'Exit' to go back to watching TV or go on to set specific parameters or controls.

Change PIN#

Press the 'Select/Ok' Button to change the pin#

HD only cable box or HD PVR box

- Press the 'Menu' or 'Settings' button
- Press the 'A' button for more settings
- Press the arrow up/down button and highlight Parental Control
- Press the 'Select/Ok' button

The following are the list of options that will come up and a description of what each option will do:

Locking Status

You can press the 'Select/Ok' button to set this to On, Off (Auto Relock), Off (Relock Manually).

Locked Channels

Press the 'Select/Ok' Button to add channels to the list.

Locked Ratings

Press the 'Select/Ok' Button to lock channels by their rating.

Locked time

Press the 'Select/Ok' Button to lock the set top for a specified time frame (can set multiple times)

Hide Adult Titles

Press the 'Select/Ok' Button to Enable/Disable this option

Lock Purchasing

- Press 'Menu' button, then Press 'A' button for more settings
- Press arrow up/down button and highlight Purchasing Press 'Select/Ok' button
- Highlight Locking Status and press 'Select/Ok'
- Highlight On and press 'Select/Ok'
- Enter your PIN# and press 'Select/Ok'

SD Cable Box

If you have one of these digital boxes, you can control what's being watched, and not watched. Follow these simple instructions to get started.

Lock Channels

Press 'Menu' or 'Settings' and then use the 'Up/Down' arrows and highlight 'Parental Control'. Press 'Ok/Select'. You'll be asked to enter your pin number. Next highlight 'Lock Channels' and press 'Ok/Select'.

Now enter the channel number you'd like blocked and press 'Ok/Select'. Now every time you, or your kids, go to those channels, you'll have to enter your pin number to proceed.

Locked Ratings

Press the 'Select/Ok' Button to lock channels by their ratings

Locked Times

Press the 'Select/Ok' Button to lock the set top for a specified time frame (can set multiple times)

Hide Adult Titles

Press the 'Select/Ok' Button to Enable/Disable this option

Lock Purchasing

- Press Menu/Settings button, press the arrow up down and highlight Purchasing
- Press the 'Ok/Select' button and enter your Pin#
- Highlight Pin Status and press 'Ok/Select'
- Highlight Pin Required and press 'Ok/Select'

Box hookups



DCT700
Cable/Antenna Hook Up



DCT700
RCA Hook Up



DCX525
Cable/Antenna Hook Up



DCX525
HDMI Hook Up

You will need

- 2 coaxial cable lines

The hook up

- Connect active cable line from wall (or floor) to “RF IN” on back of digital box
- Connect coaxial cable line from “TO TV/VCR” on box to “CABLE IN” or “ANTENNA IN” on television
- Connect supplied power cable into a live power source and into digital box
- Turn digital box on using supplied Access Communications remote
- Turn television on and tune to channel 3

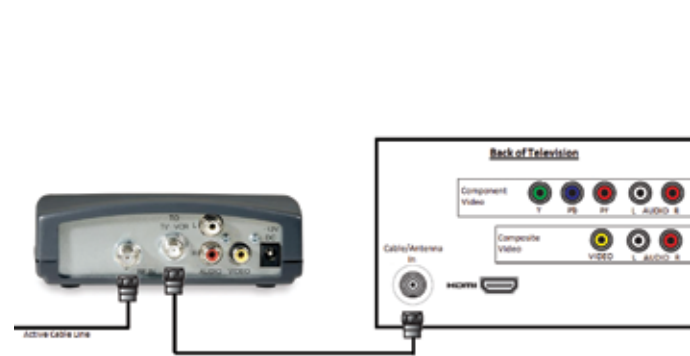

You will need

- 1 coaxial cable line
- 1 set RCA/Composite video cables

The hook up

- Connect active cable line from wall (or floor) to “RF IN” on back of digital box
- Connect one end of RCA/Composite video cables to “VIDEO” and “AUDIO” on digital box to “VIDEO IN” and “AUDIO IN” on television with corresponding colours
- Connect supplied power cable into a live power source and into digital box
- Turn digital box on using supplied Access Communications remote
- Turn television on and tune to video input

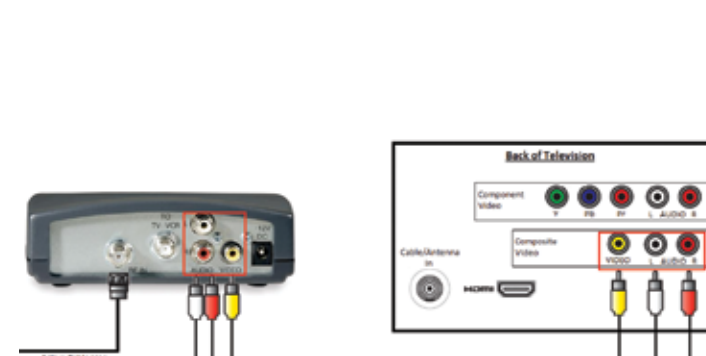

You will need

- 2 coaxial cable lines

The hook up

- Connect active cable line from wall (or floor) into “CABLE IN” on back of box
- Connect coax cable line from “RF out” on box to “CABLE IN” or “ANTENNA IN” on TV.
- Connect supplied power cable into a live power source and into digital box
- Turn digital box on using supplied Access Communications remote
- Turn television on and tune to channel 3

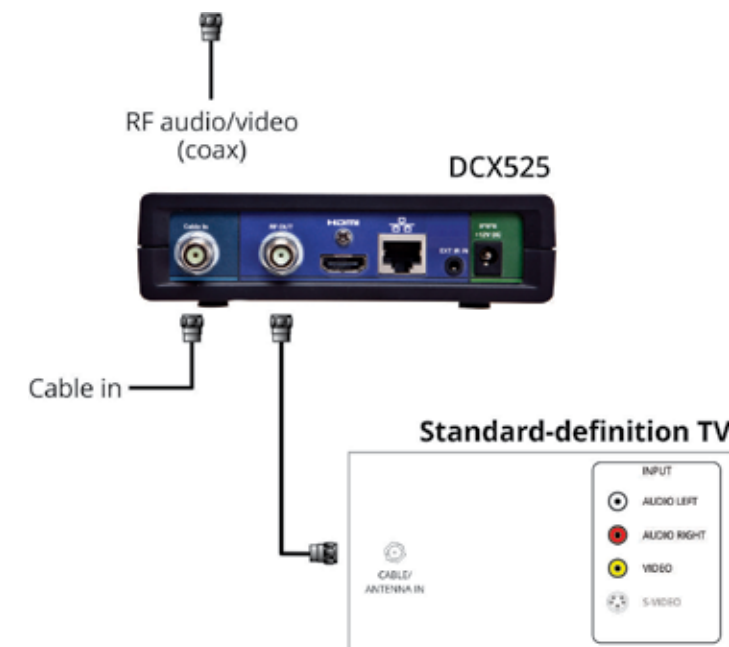

You will need

- 1 coaxial cable line
- 1 HDMI cable

The hook up

- Connect active cable line from wall (or floor) into “CABLE IN” on back of digital box
- Connect HDMI cable from “HDMI” port on back of digital box to “HDMI IN” on television
- Connect supplied power cable into a live power source and into digital box
- Turn digital box on using supplied Access Communications remote
- Turn on TV and tune to HDMI input

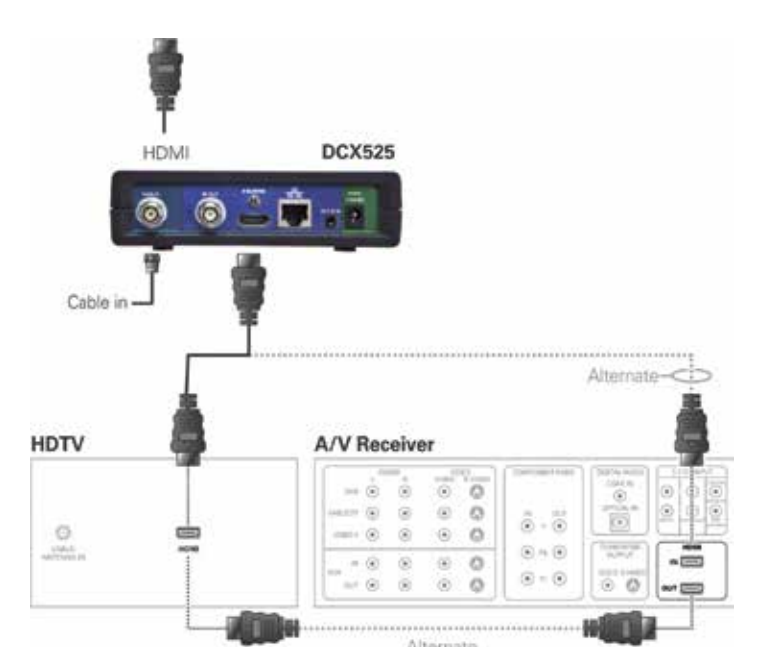



DCX700
RCA Hook Up

You will need

- 1 coaxial cable line
- 1 set RCA/Composite video cables

The hook Up

- Connect active cable line from wall (or floor) into "CABLE IN" on back of digital box
- Connect one end of RCA/Composite video cables to "VIDEO" and "AUDIO" on digital box to "VIDEO IN" and "AUDIO IN" on television with corresponding colours
- Connect supplied power cable into a live power source and into digital box
- Turn television on and tune to the Video input used
- Turn digital box on using supplied Access Communications remote

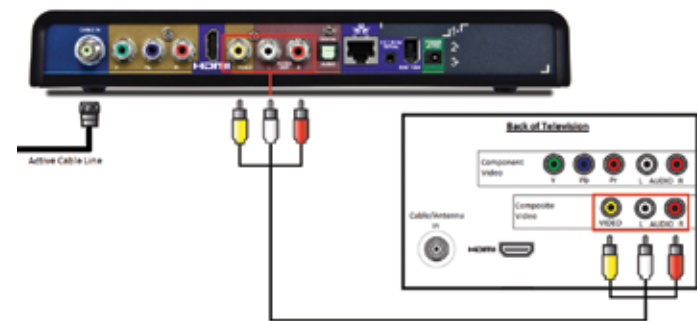

DCX700
HDMI Hook Up

You will need

- 1 coaxial cable line
- 1 HDMI cable

The hook Up

- Connect active cable line from wall (or floor) into "CABLE IN" on back of digital box
- Connect HDMI cable from "HDMI" port on back of digital box to "HDMI IN" on television
- Connect supplied power cable into a live power source and into digital box
- Turn digital box on using supplied Access Communications remote
- Turn on TV and tune to HDMI input



DCX3200
RCA Hook Up

You will need

- 1 coaxial cable line
- 1 set RCA/Composite video cables

The hook up

- Connect active cable line from wall (or floor) to "RF IN" on back of digital box
- Connect one end of RCA/Composite video cables to "VIDEO" and "AUDIO" on digital box to "VIDEO IN" and "AUDIO IN" on television with corresponding colours
- Connect supplied power cable into a live power source and into digital box
- Turn digital box on using supplied Access Communications remote
- Turn television on and tune to video input

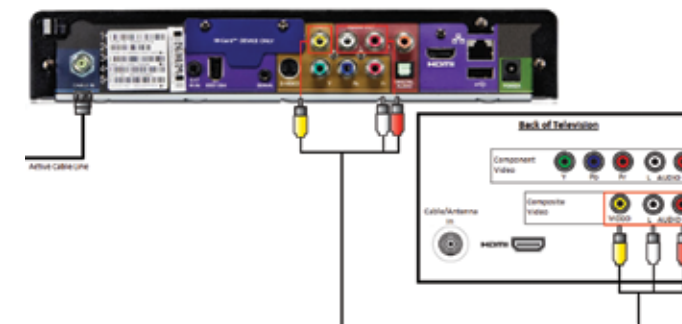

DCX3200
HDMI Hook Up

You will need

- 1 coaxial cable line
- 1 HDMI cable

The hook up

- Connect active cable line from wall (or floor) into "CABLE IN" on back of digital box
- Connect HDMI cable from "HDMI" port on back of digital box to "HDMI IN" on television
- Connect supplied power cable into a live power source and into digital box
- Turn digital box on using supplied Access Communications remote
- Turn on TV and tune to HDMI input

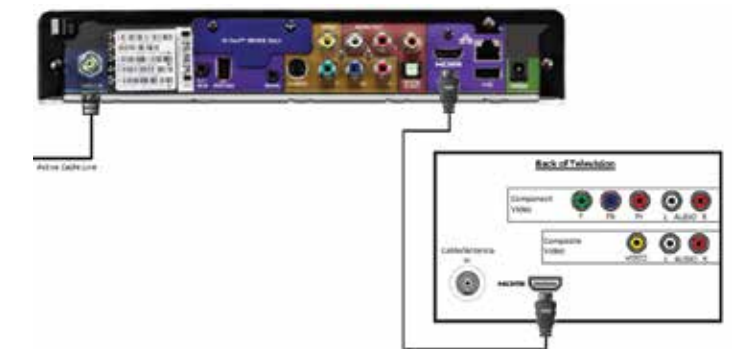



DCT3412/16

Component Hook Up

You will need

- 1 coaxial cable line
- 1 set Component cables

The hook up

- Connect active cable line from wall (or floor) to "RF IN" on back of digital box
- Connect Component cables to "Y/PB/PR" and "AUDIO" on back of box to "COMPONENT IN" on back of television with corresponding colours
- Connect supplied power cable into a live power source and into digital box
- Turn digital box on using supplied Access Communications remote
- Turn television on and tune to Component input

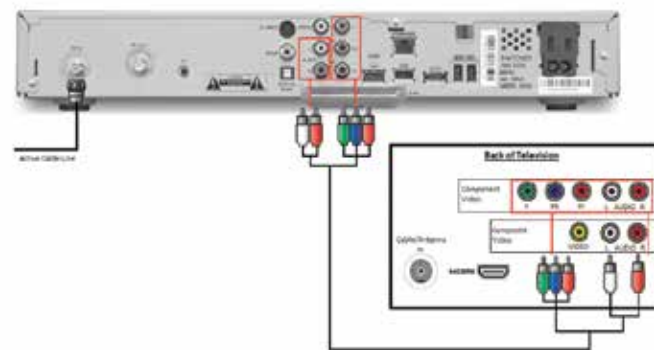

DCT3412/16

HDMI Hook Up

You will need

- 1 coaxial cable line
- 1 HDMI cable

The hook up

- Connect active cable line from wall (or floor) into "CABLE IN" on back of digital box
- Connect HDMI cable from "HDMI" port on back of digital box to "HDMI IN" on television
- Connect supplied power cable into a live power source and into digital box
- Turn digital box on using supplied Access Communications remote
- Turn on TV and tune to HDMI input

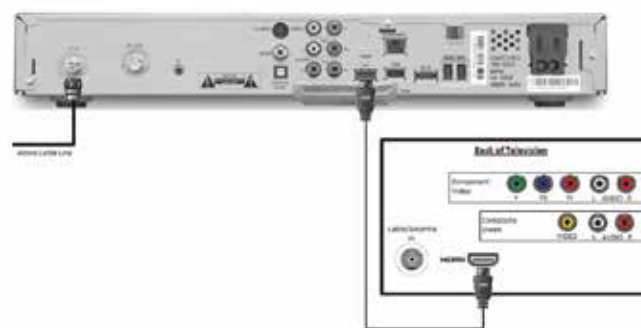

TDC777D

Component Hook Up

You will need

- 1 coaxial cable line
- 1 set Component cables

The hook up

- Connect active cable line from wall (or floor) to "RF IN" on back of digital box
- Connect Component cables to "Y/PB/PR" and "AUDIO" on back of box to "COMPONENT IN" on back of television with corresponding colours
- Connect supplied power cable into a live power source and into digital box
- Turn digital box on using supplied Access Communications remote
- Turn television on and tune to Component input

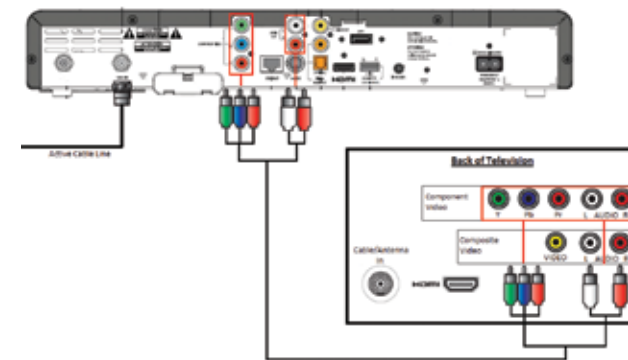

TDC777D

HDMI Hook Up

You will need

- 1 coaxial cable line
- 1 HDMI cable

The hook up

- Connect active cable line from wall (or floor) into "RF IN" on back of digital box
- Connect HDMI cable from "HDMI" port on back of digital box to "HDMI IN" on television
- Connect supplied power cable into a live power source and into digital box
- Turn digital box on using supplied Access Communications remote
- Turn on TV and tune to HDMI input

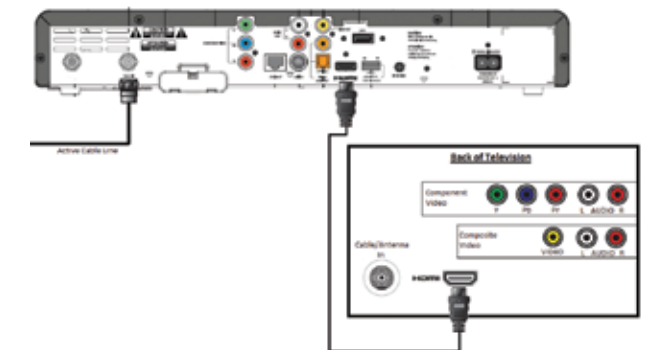



DC550D
Component Hook Up



DC550D
HDMI Hook Up



DCX3520
RCA Hook Up



DCX3520
HDMI Hook Up

You will need

- 1 coaxial cable line
- 1 set Component cables

The hook up

- Connect active cable line from wall (or floor) to "CABLE IN" on back of digital box
- Connect Component cables to "Y/PB/PR" and "AUDIO OUT" on back of box to "COMPONENT IN" on back of television with corresponding colours
- Connect supplied power cable into a live power source and into digital box
- Turn digital box on using supplied Access Communications remote
- Turn television on and tune to Component input

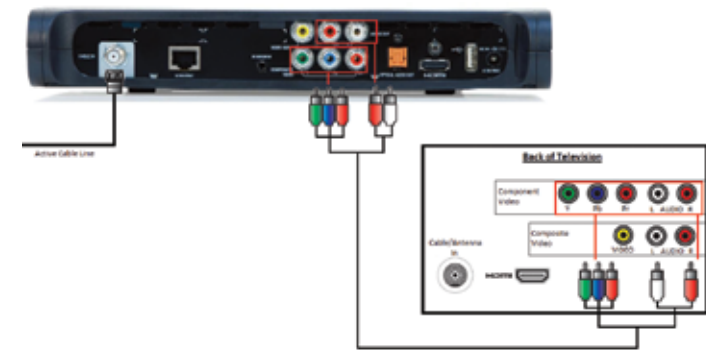

You will need

- 1 coaxial cable line
- 1 HDMI cable

The hook up

- Connect active cable line from wall (or floor) to "CABLE IN" on back of digital box
- Connect HDMI cable from "HDMI" port on back of digital box to "HDMI IN" on television
- Connect supplied power cable into a live power source and into digital box
- Turn digital box on using supplied Access Communications remote
- Turn on TV and tune to HDMI input



You will need

- 1 coaxial cable line
- 1 set RCA/Composite video cables

The hook up

- Connect active cable line from wall (or floor) to "RF IN" on back of digital box
- Connect one end of RCA/Composite video cables to "VIDEO" and "AUDIO" on digital box to "VIDEO IN" and "AUDIO IN" on television with corresponding colours
- Connect supplied power cable into a live power source and into digital box
- Turn digital box on using supplied Access Communications remote
- Turn television on and tune to video input

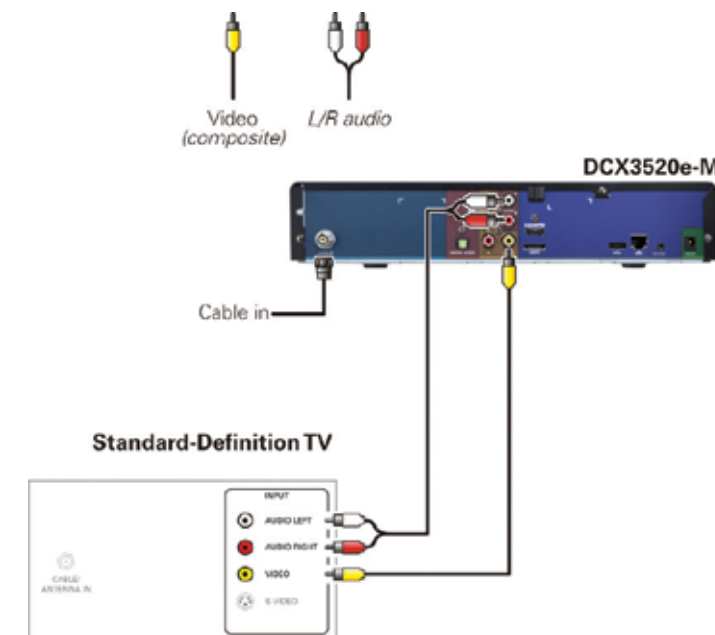

You will need

- 1 coaxial cable line
- 1 HDMI cable

The hook up

- Connect active cable line from wall (or floor) into "CABLE IN" on back of digital box
- Connect HDMI cable from "HDMI" port on back of digital box to "HDMI IN" on television
- Connect supplied power cable into a live power source and into digital box
- Turn digital box on using supplied Access Communications remote
- Turn on TV and tune to HDMI input

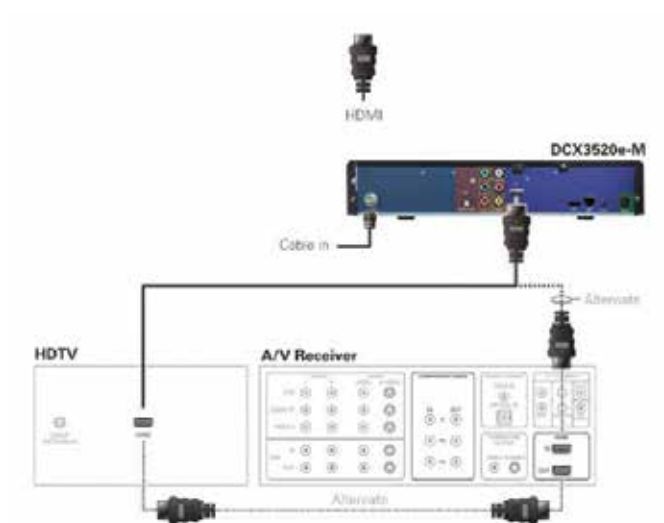



You will need

- 1 coaxial cable line
- 1 set Component cables

The hook up

- Connect active cable line from wall (or floor) into "CABLE IN" on back of digital box
- Connect Component cables to "Y/PB/PR" and "AUDIO" on back of box to "COMPONENT IN" on back of television with corresponding colours
- Connect supplied power cable into a live power source and into digital box
- Turn digital box on using supplied Access Communications remote
- Turn television on and tune to Component input

You will need

- 1 coaxial cable line
- 1 HDMI cable

The hook up

- Connect active cable line from wall (or floor) into "CABLE IN" on back of digital box
- Connect HDMI cable from "HDMI" port on back of digital box to "HDMI IN" on television
- Connect supplied power cable into a live power source and into digital box
- Turn digital box on using supplied Access Communications remote
- Turn on TV and tune to HDMI input

You will need

- 1 coaxial cable line
- 1 set RCA/Composite video cables

The hook up

- Connect active cable line from wall (or floor) to "RF IN" on back of digital box
- Connect one end of RCA/Composite video cables to "VIDEO" and "AUDIO" on digital box to "VIDEO IN" and "AUDIO IN" on television with corresponding colours
- Connect supplied power cable into a live power source and into digital box
- Turn digital box on using supplied Access Communications remote
- Turn television on and tune to video input

You will need

- 1 coaxial cable line
- 1 HDMI cable

The hook up

- Connect active cable line from wall (or floor) into "CABLE IN" on back of digital box
- Connect HDMI cable from "HDMI" port on back of digital box to "HDMI IN" on television
- Connect supplied power cable into a live power source and into digital box
- Turn digital box on using supplied Access Communications remote
- Turn on TV and tune to HDMI input

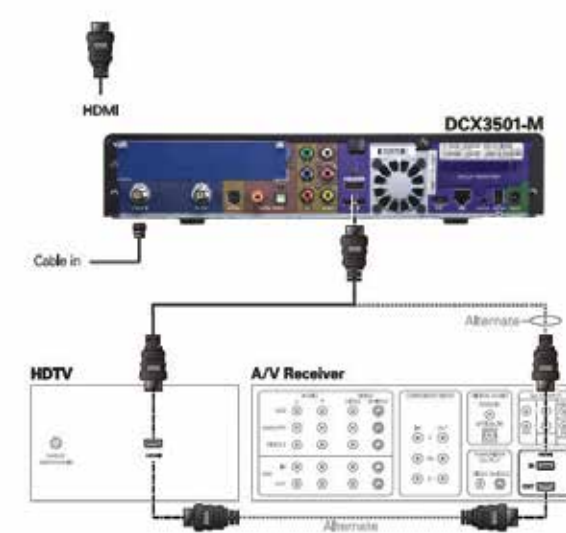
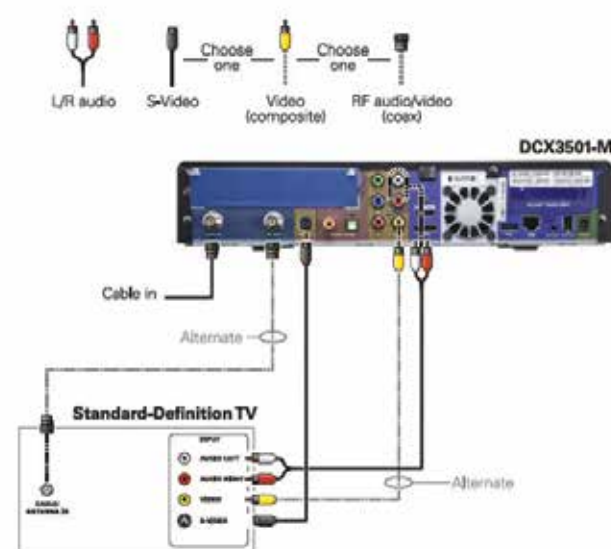
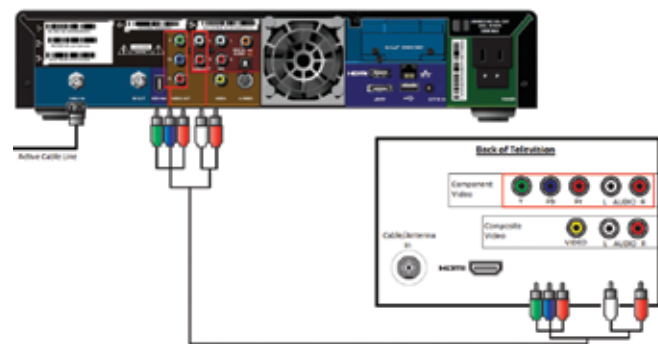

FAQs

Why is my TV only receiving static?

Often the reason for static is because the input on your TV has been changed accidentally. To change the Input, either use the original TV remote and press the 'SOURCE/INPUT/VIDEO' button until it goes back to the proper mode.

Or press the 'TV' button on your Access remote and then the 'VIDEO SOURCE' button.

How many hours can I record on my PVR?

The recording times are listed below. Times are approximate as you may be able to record more or less hours, depending on channel compression rates. Please note, all of the boxes may not be available in your community.

Box	SD	HD
Evo Gateway 500GB	300 hours	60 hours
DCX3501 500GB	300 hours	60 hours
DCX3400 250GB	150 hours	30 hours
DCX3520 500GB	300 hours	60 hours
RNG200N 500GB	300 hours	50 hours
TDC777D 250GB	150 hours	30 hours
DCT6416 160GB	95 hours	20 hours
DCT6412 120GB	72 hours	14 hours
DCT3416 160GB	95 hours	20 hours
DCT3412 120GB	72 hours	14 hours

What do I need to do to get HD service?

To get HD service you need 3 things: an HDTV, an HD digital box, and an HD package. Additional HD theme packages available.

Who do I contact about the programming on your channels?

The only channel we have control over is our own Access7 channel. Please feel free to contact us with any questions about Access7. For any other channel, please contact the network directly.

I have an HDTV and an HD digital box. I'm watching 'X' channel, and it says it's broadcasting in HD, but I'm not getting an HD picture. Why?

You have to be tuned to an HD channel to get a true HD picture. If you're watching the standard definition TSN channel, for example, even if it says it's being broadcast in HD that particular channel is broadcasting in standard definition. You'd have to tune to the HD TSN channel to see the program in HD.

Please be aware that most HD channels offer a mix of standard definition and high- definition programming. As more and more programs are being filmed in HD, the amount of true HD programming is increasing.

Why do I have to take a standard definition channel to get the HD version of that channel?

This is due to contractual requirements. Basically, the HD networks make it part of their contract that customers must subscribe to the standard definition channel to get the HD version. This is true for any company that offers HD services.

Why does a tech have to come out to install cable? Can't you just flick a switch?

Service has to be activated at the home. The technician will activate service, make sure all the outlets you want to use are working, connect any digital boxes, and verify you're getting a good signal.

How do I sign up for AccessTV ToGo?

Visit www.WatchTVEveryWhere.ca

Select your provider (Access Communications) and click on "Register", enter the required information, choose a username and password and click "Submit".

Access Communications will then automatically authenticate your details with our system and register you for the service. This process may take up to 24 hours.

You will receive your confirmation email with the activation link for you to log in to WatchTVEverywhere. All of the content that you are subscribed to will show up, just click on the link and start watching your favourite shows!

If you need assistance, please contact us at 1-866-363-2225 or email help@myaccess.coop

Can I access AccessTV ToGo anywhere?

Yes, as long as you have access to a device with an active Internet connection, you can enjoy your AccessTV ToGo service. The network apps may have restrictions built into their applications.

Can I Pause, Fast Forward, Rewind, or Scrub an AccessTV ToGo program?

Yes. These playback features are available on any supported device. (Scrubbing is the ability to move video playback forward or backward via a viewing progress bar).

Do I need to subscribe to Access Digital TV to register for AccessTV ToGo?

No, we have made AccessTV ToGo available to all of our AccessTV subscribers. Please note there are some restrictions placed on each specific network. Please check our packaging details under the Residential TV section of the website.

Do I have to be connected to AccessInternet in order to use AccessTV ToGo?

No, a subscription to AccessInternet is not required, however for an optimal connection AccessInternet should be considered. Please call one of our friendly customer care agents at 1-866-363-2225 to learn more about our Internet packaging and promotions.

What Internet speeds are required to run AccessTV ToGo services?

We recommend AccessHyperSpeed for optimal service or the fastest speed package available in your community.

FAQs

I subscribe to AccessInternet will AccessTV ToGo count toward my monthly usage?

Yes, if you are accessing AccessTV ToGo from your home Internet connection. However, if you access AccessTV ToGo while connected to a different provider (your mobile phone provider, for example), it will impact any usage plans you have with that provider instead. As always, you can view your data usage on Account Online to keep an eye on your daily, weekly and monthly usage totals.

Is AccessTV ToGo available in HD?

Yes. Any program that we offer the content in HD via Digital TV, will be streamed in HD via AccessTV ToGo as well.

Will AccessTV be adding more content than what is currently available?

Yes, please check back regularly for additional updates and new services.

My WatchTVEverywhere account is registered under my spouse's/partner's name. Can I register for WatchTVEverywhere with my own or someone else's name?

The authentication process that occurs when you register for the service validates the account number and the last name on the account against your account's billing information. Those details must therefore match your bill. The name you register with, however, can be anything you want and you can add up to 4 users.

Can I have more than one username set up for AccessTV ToGo?

Yes you can have up to 4 additional users per account.

I've entered all of the required registration details, why am I still getting an error message?

It's possible that some of the information has been mistyped. Please double-check to ensure your account number and last name match your account details.

If the problem persists, please contact our friendly customer care agents at 1-866-363-2225 for help.

When I try to login to AccessTV ToGo (WatchTVEverywhere.ca), it says that my username or password is incorrect. What can I do?

Your username will always be the email address you entered when you registered for AccessTV ToGo, whether that's an Access email address or otherwise. This cannot be changed. Check to see if you have mistyped it and try again.

To reset your password, click on the "Forgot Password" option. After correctly answering the security question you set up when you registered for WatchTVEverywhere, you will immediately be sent an email that contains a link to reset your password.

Why am I experiencing poor sound quality when viewing programs via AccessTV ToGo?

If you have external speakers for your device, make sure they are plugged in and turned on.

Check the volume level on the AccessTV ToGo video player. Make sure it's set to an acceptable level and not too low/loud or mute.

Check the volume on your device itself. Make sure it's functioning properly and set to an acceptable level (not too low/too loud/mute).

If the problem persists, try closing your web browser completely and then opening it back up again and logging back in to AccessTV ToGo.

If the problem persists, try turning your device/computer off completely and turning it back on again.

What are the minimum operating service requirements for AccessTV ToGo?

Minimum Operating System Requirements for PC and Mac:

- Windows XP Service Pack 3
- Windows Vista
- Windows 7
- Windows 8
- MacOS 10.6 Leopard and all subsequent versions.

The following web browsers are also required:

- Internet Explorer version 8+
- Mozilla Firefox version 6+
- Mac Safari version 5+
- Google Chrome version 16+

With all supported web browsers, Silverlight and/or Adobe® Flash® Player are required. iPhone or iPad with iOS 4.3+ , Android phone with OS 2.2+ , Android tablets with OS 3.0+. At this time, Blackberry and Linux devices are not supported.

For more info visit us at myaccess.ca

Digital Boxes

Serial Numbers and Room Locations

Serial Number	
Location	Remote Set Up Code

Serial Number	
Location	Remote Set Up Code

Serial Number	
Location	Remote Set Up Code

Serial Number	
Location	Remote Set Up Code

Serial Number	
Location	Remote Set Up Code



INTERNET | TV | PHONE | SECURITY

myaccess.ca | 1-866-363-2225